

VRLA Rechargeable Battery

BP230-12 (BP230-12FR)



FEATURES

- Maintenance free(no water topping-up required).
- No free acid(Non-spillable battery).
- Low self-discharge rate, lower than 3% capacity loss per month.
- Can be used in any orientation(excluding used inverted).
- Flame-arrestor is installed to ensure safety.
- Carry handles for easy installation.
- Absorbent Glass Mat technology for efficient gas recombination.

APPLICATION

- UPS
- Telecom



SPECIFICATIONS

Nominal Voltage	12 V
Nominal Capacity	230Ah @ 20 hour rate F.V.(1.75V/cell)
Approx. Weight	72.5Kg(159.8lbs.)
Terminals	B9 (Fitting M8 bolt & nut) I3 is optional
Internal Resistance	≤2.5mΩ (Fully Charged)
Max. Discharge Current	800 A (5 sec.)
Max. Charge Current	69 A
Operating Temperature Range	Charge : 0°C~40°C(32°F~104°F) Discharge : -20°C~50°C(-4°F~122°F) Storage. : -20°C~40°C(-4°F~104°F)
Container Material	ABS(UL94-HB, UL94-V0 is optional)

ISO 9001	
ISO14001	
UL	
CE	
<ul style="list-style-type: none"> ● IEC 60896-21/22 ● JIS C 8704-2 ● GB/T 19638.2 	

DIMENSION(mm/inch)

OUTER DIMENSIONS

TERMINAL TYPE

- **Length**
522±2.0 (20.55±0.08)
- **Width**
240±2.0 (9.45±0.08)
- **Container Height**
216±2.0 (8.50±0.08)
- **Total Height**
B9:240±2.0 (9.45±0.08)
I3:220±2.0 (8.66±0.08)

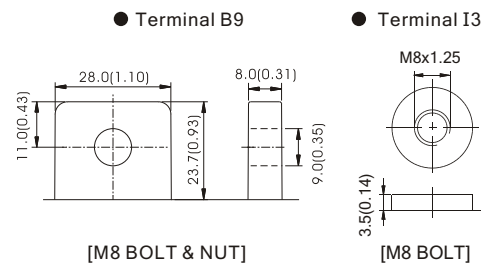
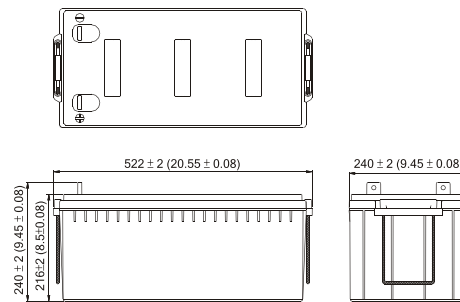

Terminal Hardware Initial Torque: B9,I3(10.0Nm±5%)

Constant power discharge characteristics at 25 °C/77 °F Unit: W

F.V. (V/cell) \ Discharge Time	15 Min	30 Min	1 Hr	3 Hr	5 Hr	10 Hr	20 Hr
1.80V	4283	2918	1674	670.3	462.3	258.3	135.9
1.75V	4480	3029	1724	683.8	469.2	262.2	138.0
1.70V	4618	3098	1755	690.0	471.8	263.5	138.7
1.65V	4724	3141	1776	694.9	473.5	264.2	139.1
1.60V	4819	3174	1794	698.9	474.8	264.2	139.1

Constant current discharge characteristics at 25 °C/77 °F Unit: A

F.V. (V/cell) \ Discharge Time	15 Min	30 Min	1 Hr	3 Hr	5 Hr	10 Hr	20 Hr
1.80V	372.4	247.3	140.7	55.86	38.53	21.52	11.32
1.75V	389.6	256.7	144.9	56.98	39.10	21.85	11.50
1.70V	401.6	262.6	147.5	57.50	39.32	21.96	11.55
1.65V	410.8	266.2	149.3	57.91	39.46	22.02	11.59
1.60V	419.0	269.0	150.8	58.24	39.56	22.02	11.59

All data shall be changed without prior notice, BB reserves the right to explain and update the information contained hereinto.